

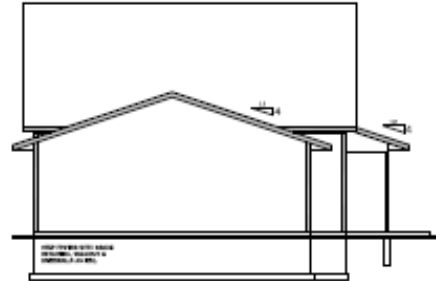

REAR ELEVATION

SCALE : 1/8" = 1'-0"



LEFT ELEVATION

SCALE : 1/8" = 1'-0"

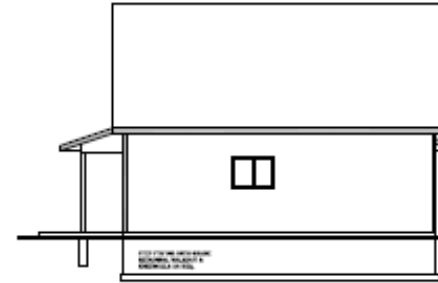

RIGHT ELEVATION

SCALE : 1/8" = 1'-0"

GENERAL CONTRACTOR NOTES:

- BEFORE STARTING PROJECT CONTRACTOR TO VERIFY ALL UNDER GROUND UTILITIES ON ALL PUBLIC OR PRIVATE PROPERTY
- SLOPE GRADE AWAY FROM HOUSE & GARAGE. PROVIDE DRAINAGE FOR ALL GROUND WATER & RAINFALL WATER AWAY FROM BUILDING, TYPICAL OF ALL SIDES.
- GUTTERS & DOWNSPOUTS NOT SHOWN. STYLE & COLOR BY OWNER.
- GUARDRAIL HEIGHT 36" MINIMUM FOR R-S/U OCCUPANCIES 4" MAX. OPENING (IRC SECTION 313)
- EGRESS AREA WELL AS REQUIRED BY IBC SECTION R310.2
- GUTTERS & DOWN SPOUTS NOT SHOWN.
- EXTERIOR FINISH, STYLE & COLOR BY OWNER.
- WINDOW/DOOR STYLES BY OWNER.
- EGRESS WINDOWS SHALL HAVE A MINIMUM NET CLEAR OPENABLE AREA OF 5.7 SQ. FT. THE MINIMUM NET CLEAR OPENABLE HEIGHT SHALL BE 20" THE MINIMUM NET CLEAR OPENABLE WIDTH SHALL BE 20". THE SILL HEIGHT SHALL BE NO MORE THAN 44" ABOVE FINISHED FLOOR. EGRESS WINDOWS SHALL BE IN ALL ROOMS LABELED AS BEDROOMS.
- PROVIDE ATTIC VENTILATION FOR IRC 806

CUSTOMER AND BUILDERS FIRSTSOURCE AGREE THAT ALL RIGHTS, TITLE, AND INTEREST IN AND TO THE PLAN PRODUCED BY BUILDERS FIRSTSOURCE FOR CUSTOMER, INCLUDING WITHOUT LIMITATION ALL COPYRIGHTS, WILL BELONG TO BUILDERS FIRSTSOURCE AND THAT SHALL HAVE A NON-EXCLUSIVE LICENSE TO COPY, MODIFY, AND USE THE PLAN AS NECESSARY FOR THE CONSTRUCTION OF ONE HOME. PROVIDED THAT CUSTOMER SHALL NOT CLAIM COPYRIGHT IN ANY SUCH MODIFICATIONS. SUCH COPYRIGHT BELONGING TO BUILDERS FIRSTSOURCE. ALL OTHER RIGHTS IN AND TO THE PLAN ARE RESERVED BY BUILDERS FIRSTSOURCE AND THE PLAN MAY NOT OTHERWISE BE ALTERED, COPIED OR REPRODUCED IN ANY FORM WITHOUT THE EXPRESS WRITTEN PERMISSION OF BUILDERS FIRSTSOURCE.



FRONT ELEVATION 8/7/2020
SCALE : 1/4" = 1'-0"

ELITE LOT 13 BLK. 2 BULL RUN

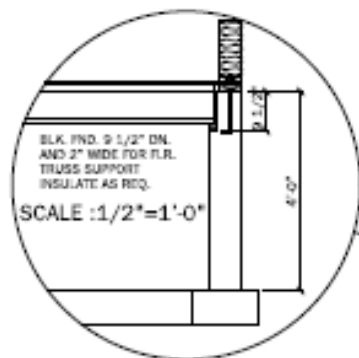

GENERAL CONTRACTOR NOTES:

1. SLOPE GRADE AWAY FROM HOUSE AND GARAGE. PROVIDE POSITIVE DRAINAGE FOR ALL GROUND WATER AND RUNOFF WATER AWAY FROM BUILDING, TYPICAL OF ALL SITES.
2. STEP FTG. WITH GRADE RETAINING WALLS AS REQUIRED
3. GRADES SHOWN ARE ASSUMED. CONTRACTOR SHALL COORDINATE FOUNDATIONS & GRADE ELEVATION w/ ACTUAL H.M.S.H. SITE. CONTRACTOR IS RESPONSIBLE TO GRADE THE SITE AROUND THE PERIMETER OF THE FOUNDATION TO MAINTAIN FROST PROTECTION LEVELS OF GRADE. FOOTING/PAD SIZES TO BE DETERMINED BY SOIL CONDITIONS AND CONTRACTOR.

** WHILE EVERY ATTEMPT HAS BEEN MADE IN THE PREPARATION OF THESE PLANS TO AVOID MISTAKES, THE DRAFTSMAN CANNOT GUARANTEE AGAINST HUMAN ERROR. CONTRACTOR ON THE JOB MUST CHECK ALL DIMENSIONS AND OTHER DETAILS AND BE RESPONSIBLE FOR THE SAME.

** DO NOT SCALE DRAWINGS. DIMENSIONS GOVERN. LARGER SCALE DRAWINGS SHALL GOVERN SMALLER SCALE *

CUSTOMER AND BUILDERS FIRSTSOURCE AGREE THAT ALL RIGHTS, TITLE, AND INTEREST IN AND TO THE PLAN PRODUCED BY BUILDERS FIRSTSOURCE FOR CUSTOMER, INCLUDING WITHOUT LIMITATION ALL COPYRIGHTS, WILL BELONG TO BUILDERS FIRSTSOURCE AND THAT SHALL HAVE A NON-EXCLUSIVE LICENSE TO COPY, MODIFY, AND USE THE PLAN AS NECESSARY FOR THE CONSTRUCTION OF ONE HOME, PROVIDED THAT CUSTOMER SHALL NOT CLAIM COPYRIGHT IN ANY SUCH MODIFICATIONS, SUCH COPYRIGHT BELONGING TO BUILDERS FIRSTSOURCE. ALL OTHER RIGHTS IN AND TO THE PLAN ARE RESERVED BY BUILDERS FIRSTSOURCE AND THE PLAN MAY NOT OTHERWISE BE ALTERED, COPIED OR REPRODUCED IN ANY FORM WITHOUT THE EXPRESS WRITTEN PERMISSION OF BUILDERS FIRSTSOURCE.

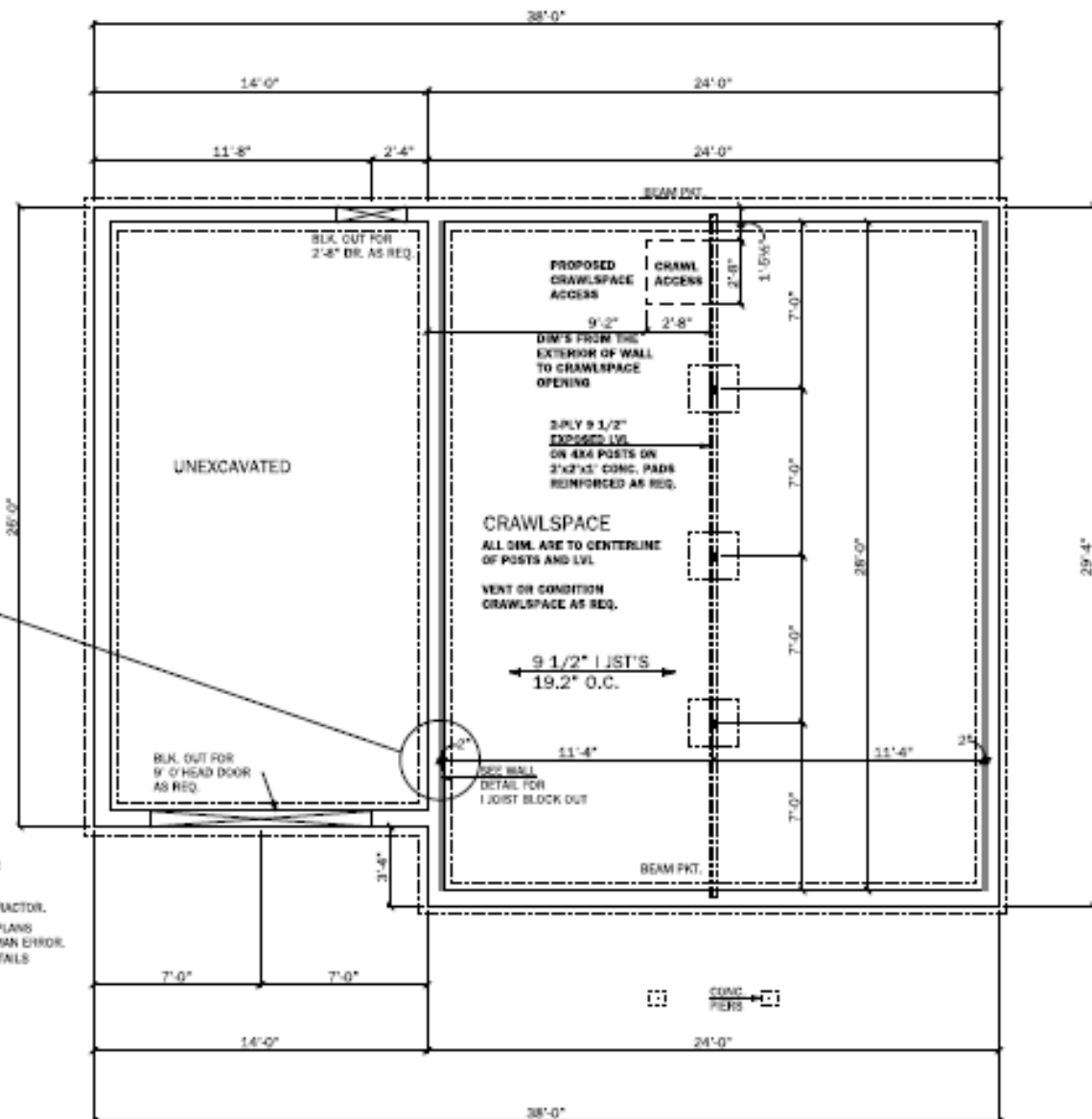

CRAWLSPACE PLAN

SCALE : 1/4" = 1'-0"

CRAWLSPACE 704 SQ. FT.

8/7/2020

1/8" = 1'-0"

GENERAL CONTRACTOR NOTES:

- DO NOT SCALE DRAWINGS. DIMENSIONS GOVERN. LARGER SCALE DRAWINGS SHALL GOVERN SMALLER SCALE.
- ALL EXTERIOR WALLS ARE 2x4 @ 16" o.c. UNLESS OTHERWISE NOTED.
- ALL INTERIOR WALLS ARE 2x4 @ 16" o.c. UNLESS OTHERWISE NOTED.
- ALL EXTERIOR HEADERS SIZED PER PLAN.
- ALL DIMENSIONS ARE FROM SURFACE OF STUD TO SURFACE OF STUD.
- CONTRACTOR TO VERIFY ALL R.O. PER WINDOW/DOOR BID SHEET.
- CONTRACTOR TO VERIFY OR SIZE ALL BEAMS.
- WINDOW STYLES BY OWNER.
- EGRESS WINDOWS SHALL HAVE A MINIMUM NET CLEAR OPERABLE AREA OF 5.7 SQ. FT. THE MINIMUM NET CLEAR OPERABLE HEIGHT SHALL BE 24" THE MINIMUM NET CLEAR OPERABLE WIDTH SHALL BE 20". THE SILL HEIGHT SHALL BE NO MORE THAN 66" ABOVE FINISHED FLOOR. EGRESS WINDOWS SHALL BE IN ALL ROOMS LABELLED AS BEDROOMS.
- PROVIDE ROOF AND SOFFIT VENTS TO ADEQUATELY VENTILATE ROOF SPACE. COORDINATE SIZE OF VENT AND LOCATIONS WITH VENT MANUFACTURER (IRC SECTION 906)

** WHILE EVERY ATTEMPT HAS BEEN MADE AVOID MISTAKES, THE DRAFTSMAN CANNOT GUARANTEE AGAINST HUMAN ERROR. THE CONTRACTOR ON THE JOB MUST CHECK ALL DIMENSIONS AND OTHER DETAILS AND BE RESPONSIBLE FOR THE SAME.

CUSTOMER AND BUILDERS FIRSTSOURCE AGREE THAT ALL RIGHTS, TITLE, AND INTEREST IN AND TO THE PLAN PRODUCED BY BUILDERS FIRSTSOURCE FOR CUSTOMER INCLUDING WITHOUT LIMITATION ALL COPYRIGHTS, WILL BELONG TO BUILDERS FIRSTSOURCE AND THAT SHALL HAVE A NON-EXCLUSIVE LICENSE TO COPY, MODIFY, AND USE THE PLAN AS NECESSARY FOR THE CONSTRUCTION OF ONE HOME, PROVIDED THAT CUSTOMER SHALL NOT CLAIM COPYRIGHT IN ANY SUCH MODIFICATIONS, SUCH COPYRIGHT BELONGING TO BUILDERS FIRSTSOURCE. ALL OTHER RIGHTS IN AND TO THE PLAN ARE RESERVED BY BUILDERS FIRSTSOURCE AND THE PLAN MAY NOT OTHERWISE BE ALTERED, COPIED OR REPRODUCED IN ANY FORM WITHOUT THE EXPRESS WRITTEN PERMISSION OF BUILDERS FIRSTSOURCE.

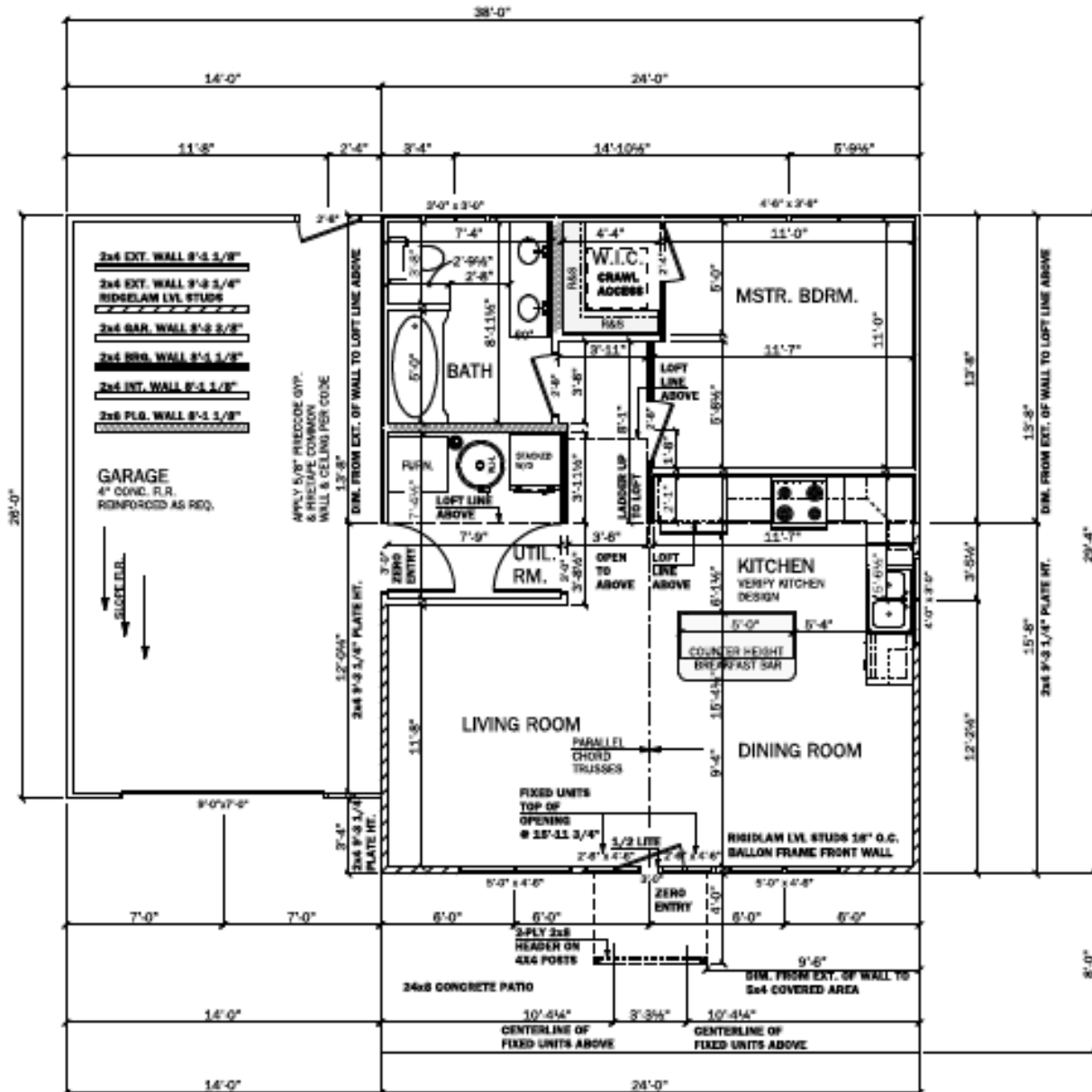

MAIN FLOOR PLAN

8/7/2020

SCALE : 1/4" = 1'-0"

MAIN FLOOR 704 SQ. FT.
GARAGE 384 SQ. FT.

1/8" = 1'-0"

CUSTOMER AND BUILDERS FIRSTSOURCE AGREE THAT ALL RIGHTS, TITLE, AND INTEREST IN AND TO THE PLAN PRODUCED BY BUILDERS FIRSTSOURCE FOR CUSTOMER, INCLUDING WITHOUT LIMITATION ALL COPYRIGHTS, WILL BELONG TO BUILDERS FIRSTSOURCE, AND THAT SHALL HAVE A NON-EXCLUSIVE LICENSE TO COPY, MODIFY, AND USE THE PLAN AS NECESSARY FOR THE CONSTRUCTION OF ONE HOME, PROVIDED THAT CUSTOMER SHALL NOT CLAIM COPYRIGHT IN ANY SUCH MODIFICATIONS, SUCH COPYRIGHT BELONGING TO BUILDERS FIRSTSOURCE. ALL OTHER RIGHTS IN AND TO THE PLAN ARE RESERVED BY BUILDERS FIRSTSOURCE AND THE PLAN MAY NOT OTHERWISE BE ALTERED, COPIED OR REPRODUCED IN ANY FORM WITHOUT THE EXPRESS WRITTEN PERMISSION OF BUILDERS FIRSTSOURCE.

ROOF IS ONLY A REPRESENTATION REFER TO MANUF. PLANS FOR ALL DETAILS

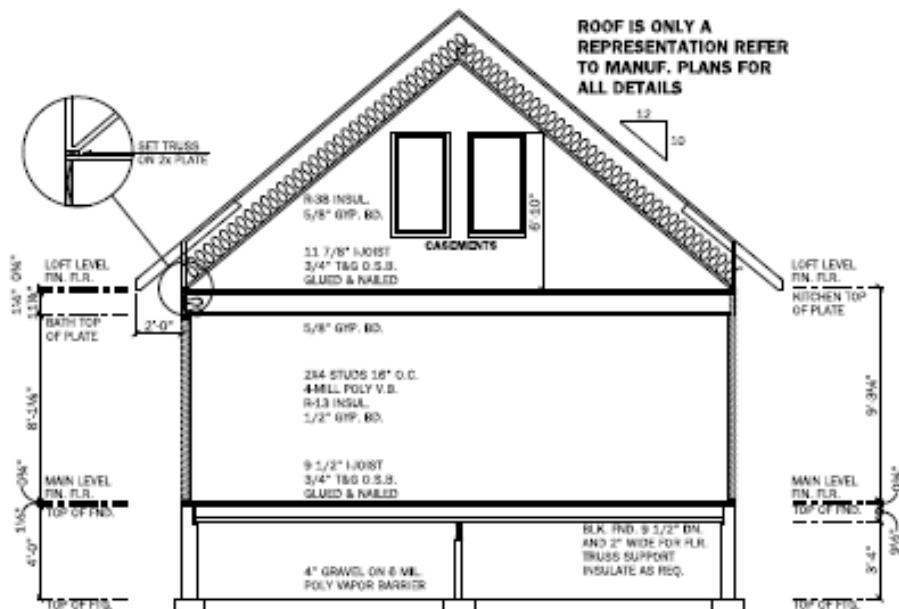

GENERAL CONTRACTOR NOTES:

1. DO NOT SCALE DRAWINGS. DIMENSIONS GOVERN. LARGER SCALE DRAWINGS SHALL GOVERN SMALLER SCALE.
2. ALL EXTERIOR WALLS ARE 2x4 @ 16" O.C.
3. ALL INTERIOR WALLS ARE 2x4 @ 16" O.C. UNLESS OTHERWISE NOTED.
4. ALL EXTERIOR HEADERS SIZED PER PLAN.
5. ALL DIMENSIONS ARE FROM SURFACE OF STUD TO SURFACE OF STUD.
6. CONTRACTOR TO VERIFY ALL R.O. PER WINDOW/ DOOR S&D SHEET.
7. CONTRACTOR TO VERIFY OR SIZE ALL BEAMS.

** WHILE EVERY ATTEMPT HAS BEEN MADE IN THE PREPARATION OF THESE PLANS TO AVOID MISTAKES, THE DRAFTSMAN CANNOT GUARANTEE AGAINST HUMAN ERROR. CONTRACTOR ON THE JOB MUST CHECK ALL DIMENSIONS AND OTHER DETAILS AND BE RESPONSIBLE FOR THE SAME.

8/7/2020
1/8" = 1'-0"